



OWNERS ASSOCIATION: ARCHITECTURAL STANDARDS & RESTRICTIONS

Last Updated 02-25-19

Approved Driveways & Sidewalks:

- **Neighborhood Standard: Broom Finish Grey Concrete**
- Stamped and Colored Concrete
- Pavers Set On Concrete and Contained Within 12" Perimeter Band Of Concrete
 - o Approved Colors: Muted Browns, Tans and Greys
- **No Asphalt Driveways or Sidewalks**

Approved Foundations:

- **Neighborhood Standard: Full Height Foundation Walls (Minimum 8' Pour)**
 - o Excludes Exterior Garage & Porch Walls
- **No Slab On Grade or Crawlspace**

Approved Exterior Finishes:

- Stone (Real or Cultured)
- Brick (Colored or Painted)
- Lap Siding (Painted or Stained)
- Shake Siding (Painted or Stained)
- Board & Batten (Painted or Stained)

Approved Exterior Siding Products:

- Natural Wood (Ex: Cedar & Redwood)
- Fiber Cement (Ex: GAF, Hardi, Allura Plycem, Woodtone)
- Engineered Wood (Ex: LP SmartSiding)
- Composites (Ex: Boral)
- **No Vinyl, PVC or Aluminum Siding**

Approved Exterior Trim Products:

- Natural Wood (Ex: Cedar & Redwood)
- Fiber Cement (Ex: GAF, Hardi, Allura Plycem, Woodtone)
- Engineered Wood (Ex: LP SmartSiding)
- Composites (Ex: Boral)
- **No Vinyl, PVC or Aluminum Trim (Except Gable Vents and Architectural Enhancing Features such as Window Crossheads, Dentil Blocks, Corbels, Decorative Brackets and Finials)**

Approved Exterior Metals:

- Painted Steel & Aluminum
- Natural Copper
- **No Unpainted Steel Intended To Rust**

Approved Garage Stalls:

- All Homes Must Have Two Enclosed Garage Stalls (Side-By-Side or Tandem)

Approved Roof Color:

- **Neighborhood Standard:** Asphalt Shingle – Driftwood

Approved Window Color:

- **Neighborhood Standard:** White
- Taupe, Tan and Brown Acceptable
- **No Black or Dark Grey Windows**

Approved Fencing:

- **Neighborhood Standard:** EADS 48" Tall S4-Saybrook Style Fencing – Black
- Fences are allowed in rear yard of homes, but must come off the rear corner of the home and travel straight back to rear building setback, at which time the fence kicks out to side at a 45 degree angle containing the 60" gate and continuing until reaching the side yard line. There are circumstances when a fence may turn perpendicular to side lot line once 5' behind neighboring home's rear setback.
- Fence must have a 60" wide gate on both sides of the house so that lawn mowing crew can easily access the property
- All Fence plans must be approved by the Design Review Committee before installation
- **No fencing is allowed in front yards or in between the homes**
- **For Installation, please contact Brian at EADS FENCE: (513) 706-9762**



Example of intended fence layout with 45 degree back swept fence & gates on both sides:







Approved Mailboxes:

- **Neighborhood Standard: Imperial C2-5105, Standard Black Box w/ 2" Bronze Numbers**
- **For Installation, please contact Beth at Mailboxes By Design: (513) 625-1409**

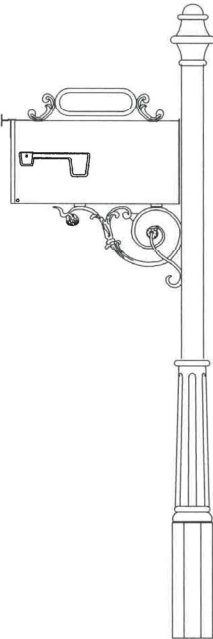

Approved Mailbox Spec:

 IMPERIAL Mailbox Systems	PO Box 340, Millbrook, AL 36054 Tel: 800-647-0777 :: Fax: 334-285-6635 Web: www.imperialmailboxsystems.com
<h2>C2-5105</h2>	
MAILBOX NOT INCLUDED	
	
<p>DIE CAST CONSTRUCTION DIRECT GROUND BURIAL MATCHING STREET SIGNS DURABLE ENAMEL FINISH ** RUST FREE **</p>	
<p>ORCHARD TRAIL APPROVED COLOR: BLACK</p>	
<p>Options Available: Brass Numerals Newspaper Holders</p>	
<p>USPS Standards: 42"-48" from road surface to bottom of mailbox. 6"-8" from face of curb to mailbox door.</p>	
 USPS APPROVED  IMPERIAL Mailbox Systems	 U.S. D.O.T. APPROVED
Note: USPS STD 7B Approved Mailboxes Are Required for all Residential Developments, per United States Postal Service.	
800-647-0777 www.imperialmailboxsystems.com	
<small>Copyright ©2010</small>	<small>Effective 1/1/10</small>

Landscape Irrigation:

- **Neighborhood Standard:** All homes are required to install and maintain irrigation of all lawn and landscaping in front of the home (including Autumn Blaze street trees) to maintain an appealing streetscape with green grass and healthy plantings. For this Irrigation requirement, the “Front Irrigation Zone” includes all areas in front of the home and the first 12’ along the front sides of each home.
- **Optional Irrigation:** Irrigation of side yards (behind front 12’) and backyards is encouraged, but not required by the Orchard Trail Owners Association.

If you have any questions, please reach out to:



Graeme R. Daley
Manager, Orchard Trail Owners Association, Inc.
graeme@daleydb.com
(513) 315-4447